

E xperimentální A nalýza N apětí

2004

DIGITAL DOUBLE-PROJECTOR MOIRÉ TOPOGRAPHY DIGITÁLNÍ PROJEKČNÍ MOIRÉ TOPOGRAFIE SE DVĚMA PROJEKTORY

Tomáš Rössler¹, Miroslav Hrabovský², František Pluháček³

The double-projector moiré topography is a well-known optical topographic method based on the projection of shadow or light gratings onto the measured object under various angles. There can be observed except these projected gratings another structure on the record image of result intensity field. Thanks the development of computer techniques it is possible to apply another procedure. Only original gratings are consequently recorded by the CCD. They are digitally processed and adjusted. Then the digital sum is carried out. The result moiré pattern has the better properties than the original. Further it is possible to compute right the moiré grating fringes. Such obtained fringes has the better properties than the ones obtained by the digital processing of classic moiré pattern.

Moiré topografie se dvěma projektory je známá optická topografická metoda, založená na projekci stínových nebo světelných mřížek na měřený objekt pod různými úhly. Na záznamu výsledného intenzitního pole je kromě těchto mřížek patrný ještě moiré obrazec. Díky rozvoji výpočetní techniky lze aplikovat jiný postup. Pomocí CCD kamery jsou zaznamenány postupně pouze původní mřížky, které jsou digitálně vyčištěny a upraveny. Poté je proveden jejich digitální součet. Výsledný moiré obrazec má lepší vlastnosti než původní. Dále je možné z upravených původních mřížek vypočítat přímo proužky moiré mřížky. Takto získané proužky mají zase lepší vlastnosti než proužky získané digitální úpravou klasického moiré obrazce.

Keywords *projection moiré topography, moiré grating, digital image processing*

Klíčová slova *projekční moiré topografie, moiré mřížka, digitální zpracování obrazu*

Introduction

The topography is a method giving a contour map as result. It describes the three-dimensional shape of the measured object. The result of moiré topography is the moiré grating which consists from separate moiré fringes. They represent the contours of the measured object, i.e. places with the same topographic depth from the topographic plane.

¹ RNDr. Tomáš Rössler, Ph.D.: Dept. of Experimental Physics, Natural Sciences Fac., Palacky Univ./Olomouc. 17.listopadu 50, 772 07 Olomouc, Czech Republic, phone: +420585634302, e-mail: rossler@optnw.upol.cz

² prof. RNDr. Miroslav Hrabovský, DrSc.: Joint Laboratory of Optics of Palacky Univ. and Inst. of Physics of Academy of Sciences of the Czech Republic. 17.listopadu 50, 772 07 Olomouc, Czech Republic, phone : +420585631501, e-mail: hrabovsky@optnw.upol.cz

³ Mgr. František Pluháček: Dept. of Optics, Natural Sciences Fac., Palacky Univ./Olomouc. 17.listopadu 50, 772 07 Olomouc, Czech Republic, phone +420585634310, e-mail: pluhacek@prfnw.upol.cz

Double-projector moiré topography

The double-projector moiré topography [1-3] belongs into the group of projection moiré methods. The collective aspect of every method joined in this group is the projection of the intensity grating into the measured surface so the periodic structure appears there. In case of the double-projector moiré topography the measured object is illuminated from two angles (Fig.1).

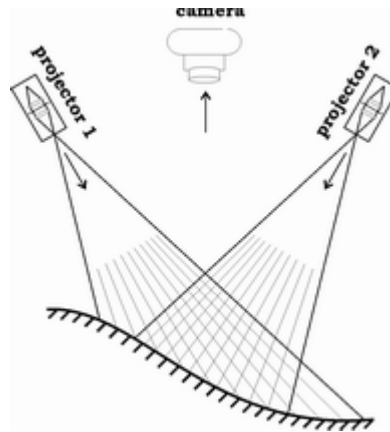

Fig.1 The measurement principle.

Intensities of both projected gratings are marked $I_1(x,y)$ and $I_2(x,y)$. Then the result observed intensity pattern is the superposition of both intensities, $I(x,y) = I_1(x,y) + I_2(x,y)$.

Experimental set-up and results

The experimental set-up on Fig.2 was designed to illustrate the above mentioned and next presented method. Here the letter B marks the measured surface or its measured part respectively. It is illuminated symmetrically from two point sources realized by a slide projector and a system of mirrors. The slide projector L is equipped with the transparent linear grating G with the micro-shifting T which realizes the shift of the grating in the direction perpendicular to fringes. The originated light grating is divided by the symmetrical divider D (the system of two perpendicular mirrors M1 and M2) into a pair of symmetrically placed mirrors M3 and M4 which reflect both beams to the measured specimen surface.

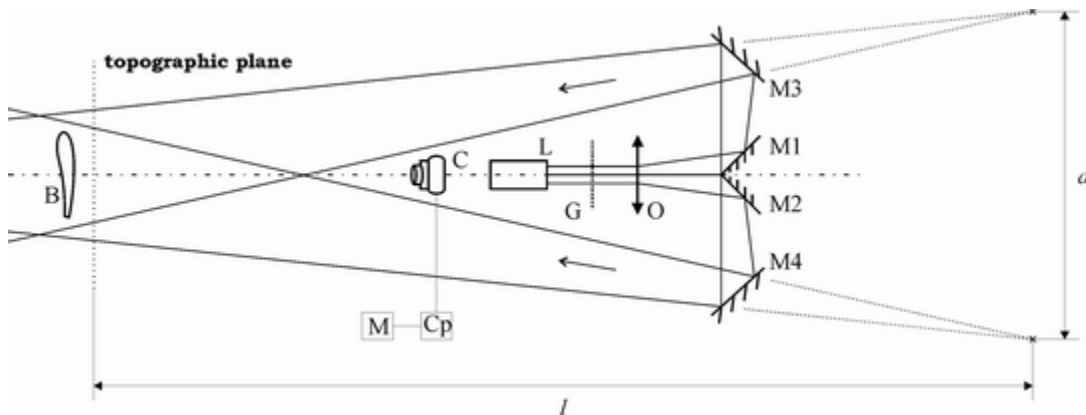

Fig.2 The possible experimental set-up.

The moiré pattern on the measured surface is recorded by the camera C. The recorded image of the moiré pattern is shown on Fig.3 (left upper side). The pump blade was used as example.

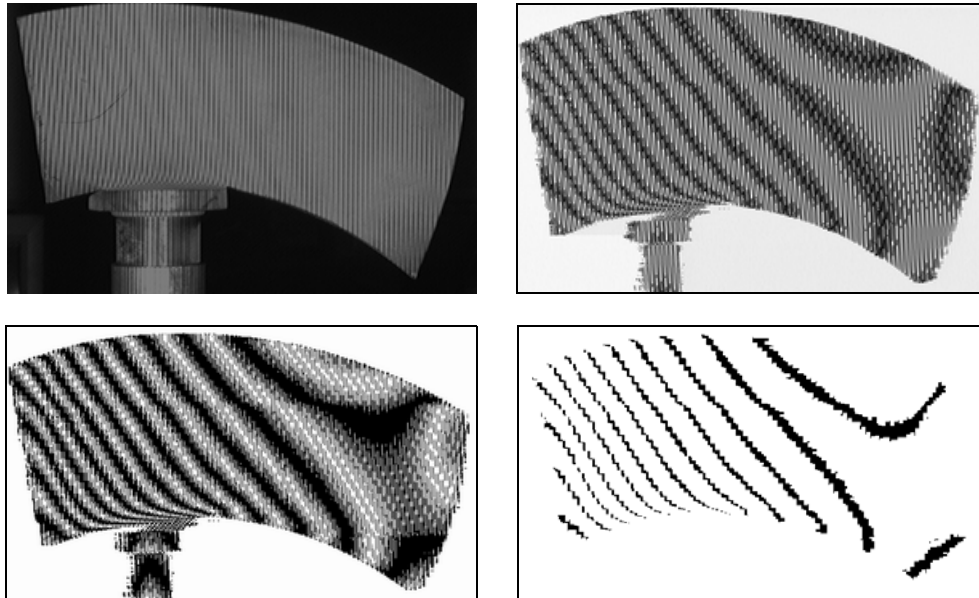

Fig.3 Original and processed images.

The moiré grating visibility on the result image is low. The original gratings fringes presence decreases it. Some method of digital processing to obtain only the moiré fringes has to be applied. The good results were obtained with processing described now.

The applied digital processing consists in a number of steps. At first the bright level adjustment is carried out (Fig.3 – right upper side). The second step is the thresholding (Fig.3 – left lower side). At the end the nonlinear space filtration was applied. The size of mask was chosen 5x3 pixels. The result is shown on Fig.3 – right lower side.

Digital double-projector moiré topography

The method consists in the separation of the process of moiré pattern creating. The camera records the whole superposition of the original grating intensities in the case of classic method. Here both projected gratings are recorded consequently (Fig.4, out side). The superposition is replaced by the digital addition of recorded images (Fig4, central).

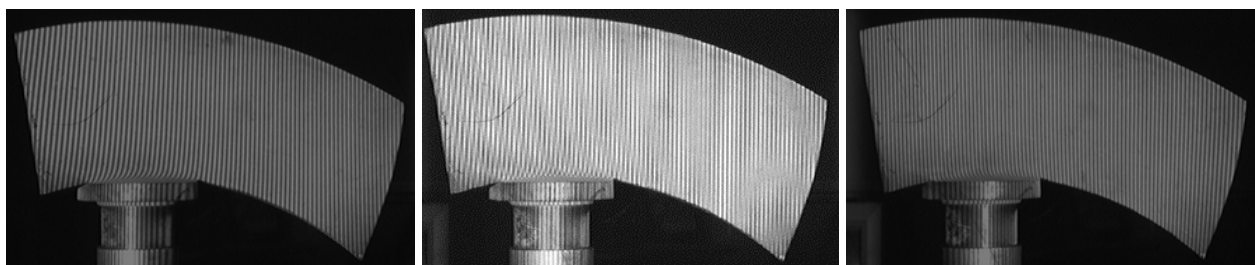

Fig.4 Recorded projected grating images and their digital sum.

The moiré grating visibility increases a little in comparison with the classic method. The above mentioned digital processing can be applied but the result moiré grating will not be too

different from the classic one. The better results are obtained using the original grating images processing.

The principle is the processing of projected gratings images. The processed gratings are very simple as ones shown on Fig.5 – left and right sides. The image processing consist in the finding of extremes in rows of pixels.

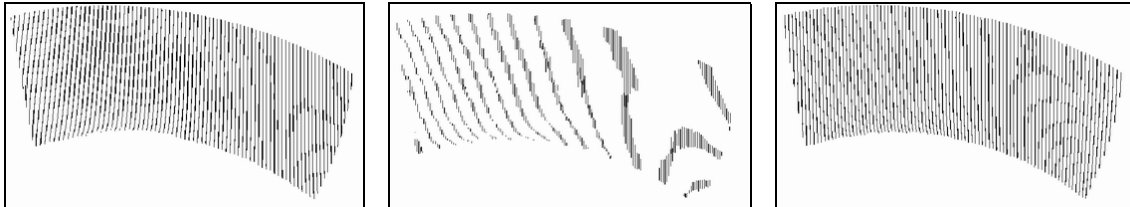

Fig.6 Processed projected gratings images and their logical combination.

At the end the logical combination of both images is applied. The moiré fringes occupy positions where both original gratings have the dark fringe. The moiré fringes are collected from short segments of a line (See Fig.6 – central).

Conclusion

The modification of classic double-projector topography method is discussed. It is called the digital one. It has the same principle but the different realization. The result moiré gratings has the similar properties. The main advantage of presented method is the simple realisation of image processing. In the classic case the special 2D software have to be used. In the case of digital modification the problem is tranfered into the 1D problem. The solution is very simple using the standard software. Then it increase the possibility of use in prectise.

Acknowledgement

That results of the project LN00A015 was supported by The Ministry of Education of the Czech Republic.

References

- [1] Rössler T.: *Modern aspects and application of moiré interferometry* [Thesis] – Palacky Univ. Olomouc, 2003, 132. (in czech)
- [2] Rössler T., Hrabovský M.: *Moiré methods for measurement of displacement and topography* – Czechoslovak Journal of Physics, 2004. (in print)
- [3] Rössler T., Hrabovský M.: *Metrological properties of moiré topography* – Proc. of Conf. on Wave and Quantum Aspects of Contemporary Optics, SPIE, Vol. **5259**, 177-185, 2003.